

A Complexity Measure for Clinical History Models

Antonio D'Uffizi, Fabrizio L. Ricci, Fabrizio
Pecoraro, Daniela Luzi, Giuseppe Stecca,
Fabrizio Consorti, Fabrizio Murgia

WORKING PAPER 138

settembre 2023

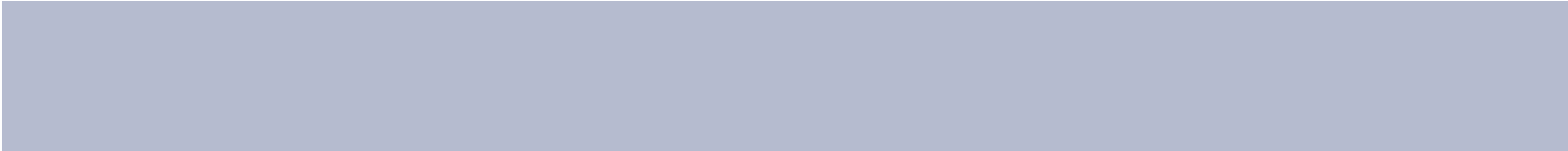

CNR – IRPPS

Una Misura di Complessità per i Modelli di Storia Clinica

Antonio D'Uffizi, Fabrizio L. Ricci, Fabrizio Pecoraro, Daniela Luzi, Giuseppe Stecca, Fabrizio Consorti, Fabrizio Murgia

2023, p. 20 – IRPPS Working papers 138/2023

Sommario: La transizione epidemiologica richiede una rappresentazione nel tempo della storia clinica di un paziente, che può essere modellata da una rete di Petri personalizzata, il grafo di Health Issue Network exemplar (HINe). Poiché HINe viene utilizzato in ambiente didattico per modellare esercizi clinici, è necessario misurare la difficoltà degli esercizi per assegnarli correttamente a discenti di diverso livello ed abilità. A tal fine, il rapporto descrive lo sviluppo di una nuova metrica per misurare la complessità strutturale di un modello HINe al fine di poter confrontare diverse storie mediche.

Parole chiave: Complessità, Reti di Petri, Problemi di Salute, Rete di Problemi di Salute

CNR – IRPPS

A Complexity Measure for Clinical History Models

Antonio D'Uffizi, Fabrizio L. Ricci, Fabrizio Pecoraro, Daniela Luzi, Giuseppe Stecca, Fabrizio Consorti, Fabrizio Murgia

2023, p. 20 – IRPPS Working papers 138/2023

Abstract: Epidemiological transition needs a representation over time of a patient's clinical history, which can be modelled by a customized Petri Net, the Health Issue Network exemplar (HINe) graph. Since HINe is used in a teaching/learning environment to model medical exercises, it is necessary to measure the exercise difficulty in order to assign them properly to learners of different level and ability. To this aim, the report describes the development of a new metrics for measuring the structural complexity of a HINe graph in order to compare different medical histories.

Keywords: Complexity, Petri Nets, Health Issue, Health Issue Network.

Citare questo documento come segue:

Antonio D’Uffizi, Fabrizio L. Ricci, Fabrizio Pecoraro, Daniela Luzi, Giuseppe Stecca, Fabrizio Consorti, Fabrizio Murgia (2023). UA Complexity Measure for Clinical History Models. Roma: Consiglio Nazionale delle Ricerche – Istituto di Ricerche sulla Popolazione e le Politiche Sociali, (IRPPS Working papers n. 138/2023, p. 20).

Indice

Index

1. Introduction	5
2. Metrics for measuring Complexity: State of the Art	6
3. HINe: A Formal Background	9
4. Methodology	11
5. Results	14
6. Discussion and Conclusions	17
References	18

1. Introduzione

A business process is a set of interrelated activities that create value by transforming resources (process input) into a final product (process output) with added value. It can be modeled through diagrams to be analyzed and improved. A Health Issue Network exemplar (HINe) diagram describes a person's health state throughout their life and how the health issues have evolved over time (Ricci *et al.*, 2018). Graphically, business process diagrams and HINe models have many similarities. Indeed, as a process diagram represents the activities and the intermediate states needed to transform resources into final product, a HINe model shows the health issues and the evolutions from one health issue to another. For this reason, the process measurement for business process model can be useful also for the evaluation of HINe models.

A process diagram is a visual process model and as such it leverages the benefits of visual languages (Moody, 2009).

In a general context, process measurement presents a set of approaches to the quantification of specific properties of processes. One of the most important properties to analyze is the estimation of complexity. The term complexity is often recurring in scientific literature, in different fields and with diverse meanings. In the dictionary, the adjective complex is defined as hard to separate, analyze, or solve (Merriam-Webster, 2022). Thus, process complexity can be defined as the degree to which a business process is difficult to analyze, understand or explain (Cardoso, 2005). Complexity can be managed by modelling the business processes as process maps and charts. The level of complexity of a business process diagram affects the time and effort one needs to invest for effective understanding, maintenance, and modification of a diagram. In order to manage and reduce the complexity of process diagrams, it is useful to measure their complexity by using metrics, which represent an indicator of whether a process diagram is easy or difficult to understand (Gruhn and Laue 2006b).

The aims of this work are to analyze the metric found in the literature and define a new metric to measure the structural complexity of a HINe model. Since the use of the HIN approach is educational, measuring the complexity has the aim of evaluating the difficulty of a clinical history (based on HINe graphs) in order to understand which types of learners the potential exercises derived from that case are suitable for. The complexity measure should not be limited to the mere structural composition of the graph, but also consider weights and measures deriving from the intrinsic complexities of the model and its components. At the moment, the metric proposed does not take into account the clinical complexity of the modeled case (rare diseases, unusual course or complications). The work is organized as follows: after the Introduction, Section 2 provides the state of the art about the existing complexity metrics and the context in which they are used; Section 3 introduces HIN as a Petri Nets-based educational tool to represent the patient's clinical history; Section 4 describes the methodology adopted to define the new complexity metric; Section 5 reports some examples of application of the new metric; Section 6 provides the discussion.

2. Metrics for measuring Complexity: State of the Art

Before to propose a metric for our scope, we investigated the existing complexity metrics and the context in which they are used. First, we reported the metrics about the business process diagrams. Then, we described the metrics specifically exploited for Petri Nets, including some metrics developed for the WorkFlow nets (WF-nets), a subclass of Petri nets with a single source place with no previous transitions, a single sink place with no following transitions, and where every node (place and transition) is on a path from source to sink.

The most of metrics in literature focused on the measurement of structural complexity of a process diagram. Some of these metrics are extensions of metrics used for the measurement of complexity in software engineering (McCabe 1976; Henry and Kafura 1981; Halstead 1987). Cardoso *et al.* (2006) adapted these metrics for measuring the complexity of process models. First, they adapted one of the earliest and fundamental measures based on the analysis of software code, that is the basic count of the number of Lines of Code (LOC) of a program, deriving from it three metrics: NOA (number of activities), NOAC (number of activities and control-flow elements), and NOAJS (number of activities, joins, and splits) in order to consider that some modeling languages allow the construction of processes that are not well-structured, where splits do not have to match a corresponding join. Second, they adapted the measure of Halstead, which are the best known and most thoroughly studied composite measure of software complexity, developed as a means of determining a quantitative measure of complexity based on a program comprehension as a function of program operands (variables and constants) and operators (arithmetic operators and keywords which alter program control-flow). In particular, they mapped the business process elements to the set of primitive measures proposed by Halstead, introducing the notion of Halstead-based Process Complexity (HPC) measures for estimating process length, volume, and difficulty). These measures for processes do not require in-depth analysis of process structures, they can predict rate of errors and maintenance effort, are simple to calculate, and can be used for most process modelling languages.

Cardoso (2005), inspired by the McCabe Cyclomatic complexity, develop a metric that could be used to evaluate processes' complexity. McCabe cyclomatic complexity is one of the most widely used software metrics related to the number of linearly independent paths through a program module and used the control-flow graph of the program. However, the McCabe Cyclomatic complexity cannot be used directly in processes since the metric ignores the semantics associated with nodes of the graph. Thus, considering the control-flow graphs to describe the logic structure of processes, he developed the Control-flow Complexity (CFC) metric based on the analysis of XOR-splits, OR-splits, and AND-splits control-flow elements.

According to Gruhn and Laue (2006b), the CFC metric is less useful to evaluate the complexity as "difficulty to understand a model". For this reason, they adapted the cognitive weight, a metric for measuring the effort required for comprehending a piece of software (Shao and Wang, 2003), to the business process models as the sum of the cognitive weights assigned to the various elements of a diagram.

Latva-Koivisto (2001) reported the Coefficient of Network Complexity (CNC) to measure the complexity of a graph, defined as the ratio of edges to nodes. In the context of a business process model, the number of edges has to be divided by the number of activities, joins, and splits (Cardoso *et al.*, 2006). From research about software complexity, the maximum nesting depth and mean nesting depth metrics are suitable for measuring the nesting of decision splits and joins, which have influence on the overall complexity of the model since a greater nesting depth implies greater complexity. In the context of business process models, the nesting depth of an action is the number of decisions in the control flow that are necessary to perform this action (Gruhn and Laue, 2006b).

Another metric is the Interface Complexity, defined by Cardoso *et al.* (2006) adapting the Information Flow Metric by Henry and Kafura to evaluate the complexity of processes, considering the inputs and outputs of activities and calculating the length of an activity using the LOC or McCabe Cyclomatic metric.

In their work, Vanderfeesten *et al.* (2008) defined the Cross-Connectivity metric to quantify the ease of understanding the interplay of any pair of a business process model elements, identifying suitable weights for nodes and edges along a path between two model elements. The Cross-Connectivity metric expresses the sum of the connectivity (i.e. the measure of the strength of the links between process model elements) between all pairs of nodes in a process model, the path with the highest connectivity between two nodes determines the strength of the overall connectivity between those nodes, the degree of connectivity is determined by the product of the valuations of the links connecting the nodes on the path, and differences in the types of nodes that a path consists of determine the degree of connectivity of the edges connecting nodes.

Most of the complexity metrics are based on one or more elements of business process model (e.g., activity, control flow elements, nesting depth, arc, cognitive weight). Many complexity metrics for business process models, as described above, considered different types of these elements. Çoşkun (2014) focused how each of elements of business process model have an impact on complexity metrics. According to cognitive weight metric (Gruhn and Laue, 2006a), every element did not have equal impact on the complex of the business process models, and different elements have different cognitive weights. Thus, the author proposed a new complexity metric for business process models considering existing complexity metrics and elements of business process model, the Cognitive Activity Depth Arc Control Flow Metric.

Finally, Rolón *et al.* (2006) defined a set of suitable metrics for the evaluation of the structural complexity of BPMN models, grouping these metrics in Base and Derived Measures. The Base Measures have been defined by counting the different kind of elements that a business process model is composed of represented with BPMN. The Derived Measures have been obtained by means of the measurement function, which establishes the existing proportions among different elements of the model. In literature, we also found two dynamic complexity metrics.

Some authors focus their work on the development of metrics for evaluating the complexity of Petri Nets. Soo and Jung-Mo (1992), following the concept of software volume from Halstead's software science theory, defined the volume (or structural size) of a Petri net as the sum of the number of places P , number of transitions T ($P \cap T = \emptyset$), and number of edges F ($F \subseteq (P \times T) \cup (T \times P)$). Moreover, since a Petri net can be considered a sort of graph, they adapted the McCabe cyclomatic complexity, where places and transitions are regarded as nodes of a graph, and arcs as directed edges.

Also Mao (2010) referred to the McCabe cyclomatic complexity to measure the structure complexity of business process represented by Petri net in Web service composition. In this context, he defined further count-based metrics: Number of places, Number of transitions, Number of services, Average degree of place and Average degree of transition, where the information of node degree in network reflects the interaction strength between nodes, and Transfer number per service since the number of transfers used to integrate a Web service into the system should be concern. Furthermore, he developed the Execution Path Complexity metric as the sum of complexities of all places and transitions (for simplicity the complexity of each place or transition was assigned with the weight 1) in an execution path, where the execution path is the sequence composed of place nodes and transition nodes. The dynamic complexity of the corresponding Web service composition can be scaled by Average Execution Path Complexity, which also considers the execution probability of each path. Next, referring to previous researches in cognitive informatics (Shao and Wang, 2003), he extended this metric by assigning different types of nodes to different weights (cognitive weights) because different place or transition node has different complexity for executing or understanding.

Tristono *et al.* (2018) investigated the complexity of the control system of the Norwegian traffic light using Petri net model. The complexity of the control system relates to the complexity characteristics of the control system model. The complexity of the structure considers the sum of complexity of the elements and the complexity of the correlation, using a correlation coefficient, given by the ratio of the incoming edges and the outgoing edges of a place to the total number of connecting edges.

Finally, Lassen and van der Aalst (2009) defined a new version of the CFC metric, called Extended Cardoso Metric (ECaM), and Cyclomatic metric, called Extended Cyclomatic Metric (ECyM), for WF-nets. The ECaM metric, as for the CFC, penalizes each state by how many direct successors states it induces. The ECyM metric do not measure the actual net structure, but its reachability graph, considering which states can the process be in and what transitions may occur. However, they criticized metrics such as CFC and Cyclomatic metric because they focus on a single aspect (behaviour or syntax of the model), and they do not consider the interaction between the different elements. Thus, the authors proposed the Structuredness Metric, defined by the sum of some "penalty" assigned to the different kinds of structures.

3. HINe: A Formal Background

A Health Issue (HI) of an individual, also denotable as a clinically meaningful, can be referred to as a disease hypothesis, a sign/symptom, a diagnosis, a risk factor, a psychological state, a social condition, or any other piece of clinically meaningful information. A HI network (HIN) describes the health status of an individual throughout their life, thus, capable to highlight how: (i) each condition has changed over time; (ii) the interactions between different health issues have influenced their evolutions; (iii) a given treatment plan for a specific condition may have turned over time into a structured treatment pathway.

In the HIN model, a health issue can: (i) evolve (spontaneously or after treatment) either to worsen or to improve; (ii) generate another clinical condition (although remaining active) as a complication/cause or catalyse as co-morbidity the evolution of another problem; (iii) relapse after resolution. It is also possible for a health issue to undergo an examining in-depth evolution, which points out the shift from: (i) the symptom reported by the patient, or a sign detected by the physician, to a diagnostic hypothesis or a diagnosis; (ii) a diagnostic hypothesis to a diagnosis, using a diagnostic test (laboratory, imaging, functional); (iii) a diagnosis to another one, whereas the first one turned out to be incorrect. From a teaching viewpoint, the clinical history of a patient, to be modelled via HIN, has the following main characteristics (Ricci, Consorti, *et al.*, 2020):

1. It is based on two fundamental concepts, HI and evolution. The transition from one HI to another occurs through a well-defined evolution;
2. It is generated by the entire additional set of evolutions connecting the patient's HIs. At any given time, the set of active HIs identify the specific health status of the patient: this implies that the clinical history can be considered as a linear system;

Given these premises, an effective alignment was acknowledged between the requirements of the HIN model and the properties of a Petri Net (PN), which is a directed graph with two types of nodes, places and transitions, connected by directed edges (Peterson, 1981; Reisig, 2012). In particular, the HIN model is characterised by two main concepts: (i) PNs' place nodes refer to the HIs; (ii) PNs' transition nodes describe the evolutions between HIs. Detailed information describing both places (HIs) and transitions (evolutions) are collected in specific data forms which state: (i) for each HI, the clinical data characterising the problem and the diagnostic–therapeutic procedures initiated due to the presence of the HI itself; and (ii) for each evolution, the threshold values of clinical parameters, which identify the evolution itself. Another important feature inherited by the Petri Net paradigm is the possibility of marking each HI node with a token: this means that the patient is interested by that specific issue at a precise moment. The distribution of tokens over the HIs work out a configuration of the network—called marking—that represents the current overall health status of the subject. Similar to what happens for PNs, a transition/evolution is considered enabled and can be fired when all its input HIs contain a token. Tokens migrate from all the input nodes of the transition to all its output nodes, thus, setting up a new configuration of the network that represents the new current health status of the subject. Since each HI node can contain only one token per time, HIN is technically a 1-bounded Petri Net or safe net. Moreover, the execution of the HIN is non-deterministic: when multiple transitions are

enabled at the same time, they will fire in any order. For a more detailed discussion of the HIN model, see (Ricci, Pecoraro, *et al.*, 2020).

The adoption of PN's formalism provides HIN with the capability to evaluate anonymized real/realistic cases and to generate timely exercises that make possible an effective discussion on the clinical case itself.

In order to be compliant with the case of a generic person, a real clinical case (i.e., of a specific person) must present a graph (set of diagnoses and relative temporal ordering) which is consistent with a possible dynamic execution of the graph of the corresponding generic evolution (respecting the transition conditions). This means that the execution of a HIN generates the evolution of the problems of a specific citizen. This evolution can be modeled and represented with a HINe (Health Issue Network exemplar) graph which may be contained in the HIN graph itself. A HINe diagram has the following constraints:

- HINe is a safe (binary) net;
- HINe can have isolated nodes (i.e., non-developing HIs);
- Minimum HINe consists of only one HI node;
- HINe is a diagram with direct edges;
- HINe can be unconnected, i.e., made up of both several connected diagram parts (one per each developing HI) and isolated nodes;
- Can exist independent subgraphs;
- In an HINe diagram there are no logical relationships of OR, XOR or combinations of logical operators between health problems entering and/or exiting evolutions, as concluded cases are modelled.
- HINe features no cycles, except for recurrences, or positive feedbacks;
- A transition can have multiple inputs and/or outputs, acting like an AND split/join, and it has to be always connected to HI nodes;
- Between two HIs (i.e., places) there can at most stand one and only one evolution (i.e., transition).
- Each transition has at least one HI place in input and one HI place in output;
- When exiting an HI node, there are no choices regarding the evolution with the input edge (i.e., an HI cannot be the input of both a worsening or an improvement or an examining in-depth).

4. Methodology

In the development of the metric to measure the complexity of a HINe model, we focused on the structural complexity of the model. For now, we did not consider the clinical aspect. Moreover, the most important elements of the model were the different types of the evolutions (see Ricci *et al.* (2018)). The metric had to have the following main characteristics: (i) reliability: consistency of the measurements made by several observers of the same process; (ii) intuitiveness: the simplicity of the complexity description and the clarity of how it connects to our intuitive understanding of complexity; (iii) modularity: ability to combine the total complexity of a process from the sub-processes; and (iv) additivity: ability to add up the complexities of successive graphs to get the complexity of the total process. On the basis of these characteristics and the constraints that a HINe diagram has to follow, in the Table 1 we reported the complexity metrics found in literature, highlighting for each whether they respected some essential parameters for the definition of our metric. In particular, if the metrics were developed for Petri nets, and possibly whether the Petri nets were safe; if the basic elements of a process diagram (e.g., nodes/places, transitions, edges, etc.) were considered; if the control-flow elements (i.e., AND, OR, and XOR) were considered, if different weights were assigned to the various elements of a diagram.

It is clear how the Extended Cardoso Metric (ECaM) (Lassen and van der Aalst, 2009) is the one that most satisfies the required parameters. As cited in Section 2, the ECaM was developed for the WorkFlow nets (WF-nets), which had structural characteristics similar to the HINe models. Moreover, the ECaM focused on the transitions of a Petri Net which fits well with our emphasized role of evolutions in a HINe model. In particular, the ECaM penalizes each place by how many direct successors places it induces; i.e., it is the number of subsets of places reachable from a place p .

As stated in Lassen and van der Aalst (2009), let $PN = (P, T, F)$ be a WF-net. $ECFC_p: P \rightarrow \mathbb{N}$ is an auxiliary function. For any $p \in P$:

$$ECFC_p(p) = |\{t \bullet \mid t \in p \bullet\}|$$

The ECaM for Petri net was defined as

$$ECam(PN) = \sum_{p \in P} ECFC_p(p)$$

The ECaM penalizes each state by how many direct successors states it induces. Following the definition of $ECFC_p$, the penalty for a place p is the number of subsets of places reachable from a place p .

However, the EcaM as it stands does not completely fit our purpose because in a HINe model the different types of transitions have a clinically oriented semantic and hence arguably not the same weight in producing complexity for a medical student. For this reason, referring to the cognitive weights described by Mao (2010), we defined a complexity weight for each possible evolution/transition (Table 2). In addition, inspired by the Cognitive Activity Depth Arc Control Flow (Çoşkun 2014), we assigned a weight also for the potential AND splits/joins because they influence the structural complexity of a HINe model (in a PN, it is represented by a transition with multiple inputs and/or outputs). These weights were

deduced inductively from the mistakes made by medical students as they attempted to complete a sample of clinical exercises that were balanced for various levels of structural complexity. We anticipated that more errors would indicate greater complexity and difficulty. After consultation with medical professionals, the weights were ultimately decided upon and stated in arbitrary units (D'Uffizi *et al.* 2023).

Table 1 - Summary Table of Metrics in literature

Author(s)	Metric	Petri Nets-based	Safe Net	Basic elements (nodes/places, transitions, edges)	Control-flow elements (AND, OR, XOR)	Weights
Soo and Jung-Mo (1992)	Volume	X		X		
Latva-Koivisto (2001)	Coefficient of Network Complexity (CNC)			X	X	
Cardoso (2005)	Control-flow Complexity (CFC)				X	
Gruhn and Laue (2006b)	Nesting Depth Metric				X	
	Cognitive Complexity Metric				X	X
Cardoso <i>et al.</i> (2006)	Number of activities (NOA)			X		
	Number of activities and control-flows (NOAC)			X	X	
	Number of activities, control-flows and joins (NOAJS)			X	X	
	Process Length (L)			X	X	
	Process Volume (V)			X	X	
	Process Difficulty (D)			X	X	
	Interface Complexity			X		
Rolón <i>et al.</i> (2006)	Complexity Metrics for BPMN			X	X	
Vanderfeesten <i>et al.</i> (2008)	Cross-Connectivity Metric (CC)			X	X	X
Lassen and van der Aalst (2009)	Extended Cardoso Metric (ECaM)	X	X	X	X	
	Extended Cyclomatic metric (ECyM)	X	X		X	
	Structuredness Metric (SM)	X	X		X	
Mao (2010)	Number of Places	X		X		
	Number of Transitions	X		X		
	Number of Services	X		X		
	Average Degree of Place (ADP)	X		X		
	Average Degree of Transition (ADT)	X		X		
	Transfer Number per Service (TNS)	X		X		
	Average Execution Path Complexity	X		X		X
Çoşkun (2014)	Cognitive Activity Depth Arc Control Flow (CADAC)			X	X	X
Tristono <i>et al.</i> (2018)	Structural Complexity (Cs)	X		X		

Table 2 - Complexity Weights

HINe Element	Weight
Worsening	1
Improvement	1
Persistence	1
Examining in-depth	2
Complication	2
Cause	2
Recurrence	3
Co-morbidity	3
Co-presence	3
AND splits/joins	2
Cycle	3
Positive Feedback	3

Unlike WF-nets, the HINe models can have isolated nodes. Thus, using the current formula of ECaM, the complexity of an isolated node/HI would be zero. Moreover, another issue of the ECaM is that for the AND-splits the ECaM (PN_{AND}) is simply 1. Instead, in a medical context, the number of the outgoing HIs from an AND-split is crucial and can affect the model complexity. Finally, in HINe models there are neither OR splits nor XOR splits since HINe represents a clinical history that already occurred. In order to overcome these concerns, referring to the Number of Places of count-based metric in Mao (2010), we decided to also consider the number of HIs/places in the model.

Considering all these aspects, let $PN = (P, T, F)$ a HINe model, we defined the metric for measuring the complexity of a HINe model as:

$$HIC = \sum_{p \in P} \sum_{t \in p \bullet} W_e(\mu(f)) + \sum_{a \in A} W_a(a) + \sum_{b \in B} W_b(b) + \sum_{d \in D} W_d(d) + |P| + |T|$$

where

- P , the finite set of places/HIs, with $P \neq \emptyset$;
- T , the finite set of transitions/evolutions;
- $F \subset (P \times T) \cup (T \times P)$, the finite set of edges, with $P \cap T = \emptyset$;
- $\mu: F \rightarrow E$, label function with $E = \{\text{examining in-depth, worsening, improvement, complication, recurrence, cause, co-morbidity, co-presence}\}$;
- A , the finite set of AND splits/joins, with $A \subseteq T$;
- B , the finite set of cycles;
- D , the finite set of positive feedbacks;
- $W_e: E \rightarrow \mathbb{N}$, the function of the complexity weight of a transition/evolution label (see Table 2);
- $W_a: A \rightarrow \mathbb{N}$, the function of the complexity weight of an AND split/join (see Table 2);
- $W_b: B \rightarrow \mathbb{N}$, the function of the complexity weight of a cycle (see Table 2);
- $W_d: D \rightarrow \mathbb{N}$, the function of the complexity weight of a positive feedback (see Table 2).

We note that let p be a place, the formula $\sum_{t \in p \bullet} W_t(t)$ calculates the total weight of transitions/evolutions, output of place p ($t \in p \bullet$).

5. Results

Once we defined the new metric for measuring the complexity of a HINE model, we applied the formula separately to potential evolutions of a HINE model. The following Table 3 shows some particular cases.

Table 3 - Complexity for different types of evolutions

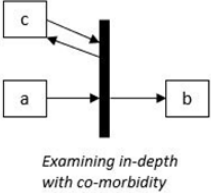
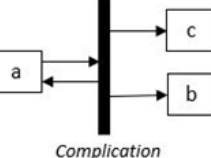
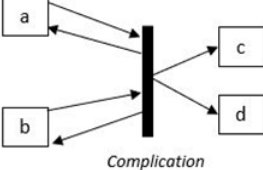
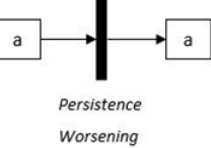
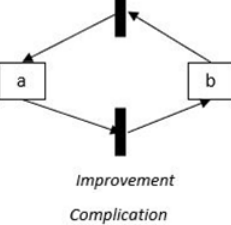
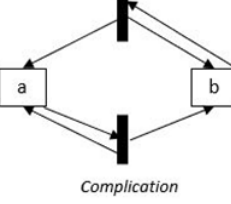
Case	HINE	Complexity
(1)	 <p>Examining in-depth with co-morbidity</p>	$HIC = W_t(t_1) _{t_1 \in a^*} + \emptyset _{b^*} +$ $W_t(t_2) _{t_1 \in c^*} + W_a(a) * A + P +$ $ T = 2 + 0 + 3 + (2 * 1) + 3 + 1 = 11$
(2)	 <p>Complication</p>	$HIC = W_t(t_1) _{t_1 \in a^*} + \emptyset _{b^*} + \emptyset _{c^*} +$ $W_a(a) * A + P + T = 2 + 0 + 0 +$ $(2 * 1) + 3 + 1 = 8$
(3)	 <p>Complication</p>	$HIC = W_t(t_1) _{t_1 \in a^*} + W_t(t_1) _{t_1 \in b^*} +$ $\emptyset _{c^*} + \emptyset _{d^*} + W_a(a) * A + P + T =$ $2 + 2 + 0 + 0 + (2 * 1) + 4 + 1 = 11$
(4)	 <p>Persistence Worsening</p>	$HIC = W_t(t_1) _{t_1 \in a^*} + \emptyset _{a^*} + P +$ $ T = 1 + 0 + 2 + 1 = 4$
(5)	 <p>Improvement Complication</p>	$HIC = W_t(t_1) _{t_1 \in a^*} + W_t(t_2) _{t_2 \in b^*} +$ $W_b(b) * B + P + T = 1 + 1 + (3 *$ $1) + 2 + 2 = 9$
(6)	 <p>Complication</p>	$HIC = W_t(t_1) _{t_1 \in a^*} + W_t(t_2) _{t_2 \in b^*} +$ $W_d(d) * D + P + T = 2 + 2 + (3 *$ $1) + 2 + 2 = 11$

Both cases (1) and (2) contain both three HIs, one evolution, and one AND, but the measurement process of the complexity is different, mainly due to the type of AND in the two

cases. Indeed, in case (1) the transition is an AND join with two ingoing edges (i.e., examining in-depth and co-morbidity) that contribute to the complexity measurement with their respective weights (see Table 1). In case (2), the transition is an AND split; thus for measuring the complexity only the weight of the ingoing edge (i.e., complication) is considered. Then, following this reasoning, for measuring the complexity of the case (3) we need to consider only the weight of the ingoing complications to the transition, in addition to the number of HIs, evolutions and the AND.

Case (4) shows the measurement of complexity for the persistence. The peculiarity of this case is that just one HI needs to be considered, despite the evolution is represented by twos. This is because the condition remains the same during time.

Finally, cases (5) and (6) show how to apply the formula for cycles/positive feedbacks. In these cases, in addition to the number of HIs and evolutions and the weight of the edges, we need to consider also the weight assigned to a cycle/positive feedback.

Next, we measured the complexity of two representative HINe models to show the adoption of the defined metric in order to compare complete clinical histories from the perspective of structural complexity.

Figure 1 – First example of a HINe model (Case 1)

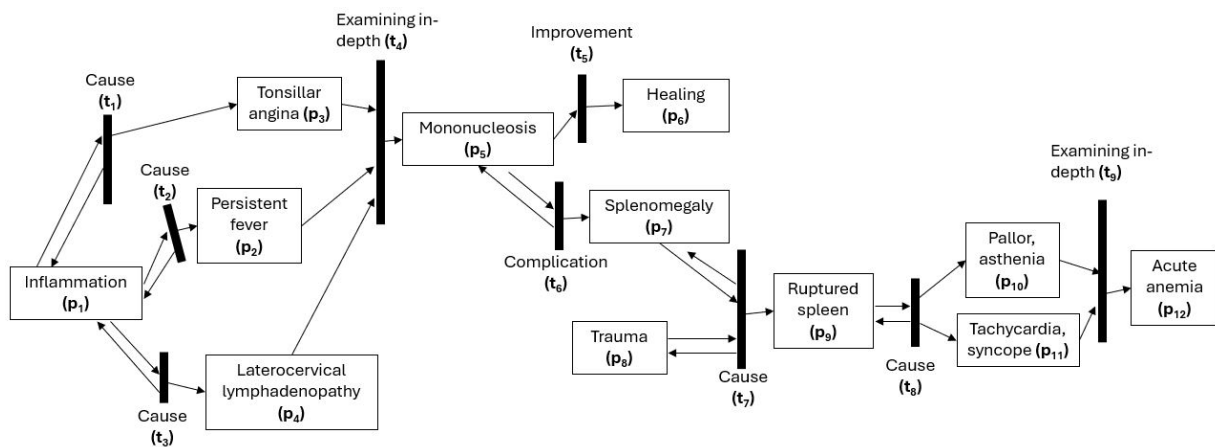

Figure 2 - Second example of a HINe model (Case2)

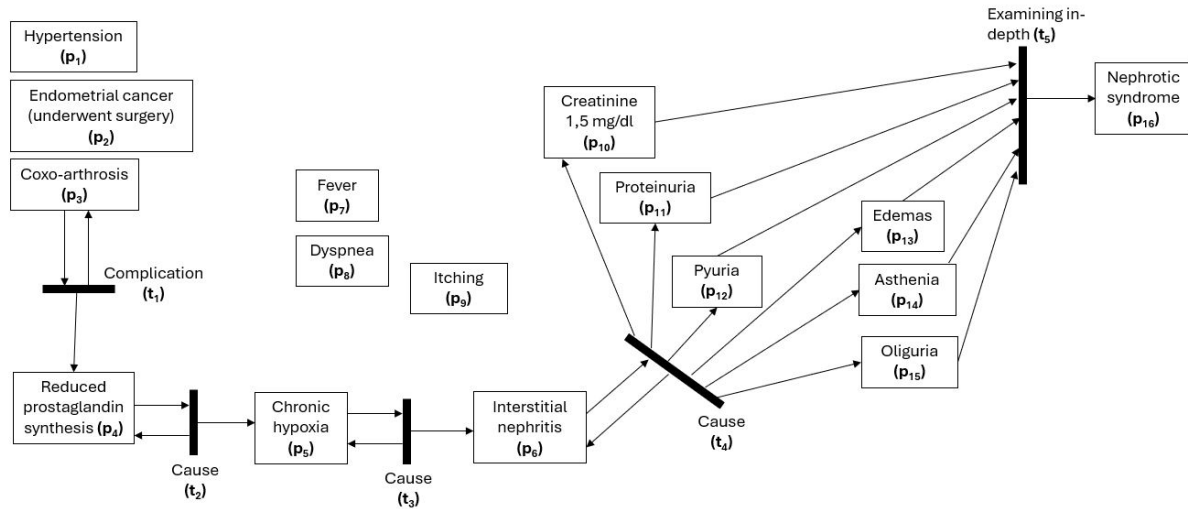

Figure 1 shows a first example of the HINe graph modeling a patient who develops, over time, mononucleosis and trauma with spleen rupture causing acute anemia. Note that each HI is identified by a label p_i , while each transition is identified by a label t_i .

Since there are four AND splits/joins with the same weight, no cycles/positive feedbacks, twelve HIs, and nine transitions, the formula becomes:

$$\begin{aligned}
 HIC_{Case\ 1} = & W_t(t_1)|_{t_1 \in p_1} + W_t(t_2)|_{t_2 \in p_1} + W_t(t_3)|_{t_3 \in p_1} + W_t(t_4)|_{t_4 \in p_2} + W_t(t_4)|_{t_4 \in p_3} + \\
 & W_t(t_4)|_{t_4 \in p_4} + [W_t(t_5)|_{t_5 \in p_5} + W_t(t_6)|_{t_6 \in p_5}] + W_t(t_7)|_{t_7 \in p_7} + W_t(t_7)|_{t_7 \in p_8} + W_t(t_8)|_{t_8 \in p_9} + \\
 & W_t(t_9)|_{t_9 \in p_{10}} + W_t(t_9)|_{t_9 \in p_{11}} + W_a(a) * |A| + |P| + |T| = 2 + 2 + 2 + 2 + [1 + 2] + 2 + 2 + \\
 & 2 + 2 + 2 + 2 * |\{t_4, t_7, t_8, t_9\}| + |\{p_1, p_2, p_3, p_4, p_5, p_6, p_7, p_8, p_9, p_{10}, p_{11}, p_{12}\}| + \\
 & |\{t_1, t_2, t_3, t_4, t_5, t_6, t_7, t_8, t_9\}| = 54
 \end{aligned}$$

where the term $W(t)|_{t \in p}$ shows which HI each transition/evolution refers to. It is clear from the example that the greatest weight depends on the fact that each AND split/join is calculated three times: (1) as a single transition (with the weight of the type of evolution) for each input HI; (2) as the weight of the AND split/join; and (3) as the number of HIs participating in the evolution. This respects, on the one hand, the importance of the influence among different HIs and, on the other hand, the difficulty of identifying these interactions.

Instead, Figure 2 shows a HINe graph modeling a patient who develops interstitial nephritis causing, over time, a nephrotic syndrome. In this case, since there are two AND splits/joins with the same weight, no cycles/positive feedbacks, sixteen HIs, and five transitions, the formula becomes:

$$\begin{aligned}
HIC_{Case\ 2} = & W_t(t_1)|_{t_1 \in p_3} + W_t(t_2)|_{t_2 \in p_4} + W_t(t_3)|_{t_3 \in p_5} + W_t(t_2)|_{t_2 \in p_4} + W_t(t_3)|_{t_3 \in p_5} + \\
& W_t(t_4)|_{t_4 \in p_6} + W_t(t_5)|_{t_5 \in p_{10}} + W_t(t_5)|_{t_5 \in p_{11}} + W_t(t_5)|_{t_5 \in p_{12}} + W_t(t_5)|_{t_5 \in p_{13}} + \\
& W_t(t_5)|_{t_5 \in p_{14}} + W_t(t_5)|_{t_5 \in p_{15}} + W_a(a) * |A| + |P| + |T| = 2 + 2 + 2 + 2 + 2 + 2 + 2 + 2 + 2 + 2 + \\
& 2 + 2 * |\{t_4, t_5\}| + |\{p_1, p_2, p_3, p_4, p_5, p_6, p_7, p_8, p_9, p_{10}, p_{11}, p_{12}, p_{13}, p_{14}, p_{15}, p_{16}\}| + \\
& |\{t_1, t_2, t_3, t_4, t_5\}| = 45
\end{aligned}$$

What emerges from the comparison of the measure of the structural complexity of these two clinical histories is that despite the Case 2 has more HIs than Case 1, these do not significantly impact the measure of complexity because of five isolated HIs. This aspect highlights the decisive role of evolutions in the measurement of complexity.

6. Discussion and Conclusions

The assessment of the difficulty of an exercise is important because it allows for providing students with exercises with a progressive cognitive load and for blending structural and clinical difficulty. For example, for a simple clinical case, a more complex exercise can be designed (an incomplete HINe diagram, in which part of the clinical history is missing and has to be drawn by the student) or for a complex clinical case, a less structurally complex exercise can be assigned (a complete HINe diagram in which only some labels of diagnosis or evolution have been omitted). Note that, in order to facilitate the design of the evolution of a patient's health status, a user-friendly representation (f-HINe, where f stand for friendly) in the HIN model was introduced (for further details see [1]). Following the review of many metrics in literature, our complexity measure was inspired by the Extended Cardoso Metric [6], which was developed for the Workflow nets (a subclass of Petri Nets) since WF-nets and HINe graphs had similar structural characteristics. In our metric we paid major attention on the components of a HINe model like the number of HIs and the different types of evolution between HIs. This study focuses only on the structural complexity of a HINe; future works should also consider the clinical difficulty (different specialties, more complex cases including rare conditions) to have an overall evaluation of complexity of a case represented with a HINe. A wider evaluation by medical students and doctors (professors, doctoral students, residents, physicians) in agreement with the Italian Society for Medical Education (SIPeM) is ongoing.

References

- Cardoso J. (2005). "Control-flow Complexity Measurement of Processes and Weyuker's Properties", in *Proceedings of World Academy of Science, Engineering and Technology* Budapest, Hungary, pp. 213-218.
- Cardoso J., Mendling J., Neumann G. and Reijers H.A. (2006). "A Discourse on Complexity of Process Models", in *Proceedings of the 2006 International Conference on Business Process Management Workshops*, Vienna, Austria, pp.117-128.
- Çoşkun E. (2014). "A new Complexity Measure for Business Process Models." Retrieved from <http://acikarsiv.atilim.edu.tr/browse/887/10045064.pdf>.
- D'Uffizi A., Pecoraro F., Ricci F.L., Stecca G., and Consorti F. (2023), "The Complexity of a Clinical History". *Studies in health technology and informatics* 302: pp.506-507.
- Gruhn V., and Laue R. (2006a). "Adopting the Cognitive Complexity Measure for Business Process Models", *5th IEEE International Conference on Cognitive Informatics* pp.236-241. doi: 10.1109/COGINF.2006.365702.
- . (2006b). "Complexity metrics for business process models", *9th International Conference on Business Information Systems*, Klagenfurt, Austria, pp.1-12.
- Halstead M.H. (1987). *Elements of Software Science*: Elsevier.
- Henry S. and Kafura D. (1981). "Software structure metrics based on information-flow". *IEEE Transactions on Software Engineering* 7 (5): pp.510-518.
- Lassen K.B. and van der Aalst W.M.P. (2009). "Complexity metrics for Workflow nets". *Information and Software Technology* 51 (3): pp.610-626. doi: 10.1016/j.infsof.2008.08.005.
- Latva-Koivisto A. (2001). "Finding a Complexity Measure for Business Process Models".
- Mao C. (2010). "Control Flow Complexity Metrics for Petri Net-based Web Service Composition". *Journal of Software* 5 (11): pp.1292-1299. doi: 10.4304/jsw.5.11.1292-1299.
- McCabe T.J. (1976). "A complexity measure". *IEEE Transactions on Software Engineering* 2 (4): pp.308-320.
- Merriam-Webster (2022). "Complex". Accessed December 12, 2022. <https://www.merriam-webster.com/dictionary/complex>.
- Moody D.L. (2009). "The Physics of Notations: Toward a Scientific Basis for Constructing Visual Notations in Software Engineering". *IEEE Transactions on Software Engineering* 35 (6): pp.756-779. doi: 10.1109/TSE.2009.67.
- Peterson J.L. (1981). *Petri Net Theory and the Modeling of Systems*: Prentice Hall: Hoboken N.J., USA.
- Reisig W. (2012). *A Primer in Petri Net Design*: Springer: Berlin/Heidelberg, Germany.
- Ricci F.L., Consorti F., Pecoraro F., Luzi D., Mingarelli V., Miotti S. and Tamburis, O. (2020). "Understanding Petri Nets in Health Sciences Education: The Health Issue Network Perspective". *Studies in health technology and informatics* 270: pp.484-488. doi: 10.3233/SHTI200207.

- Ricci F.L., Consorti F., Pecoraro F., Luzi D., Mingarelli V. and Tamburis O. (2018). "HIN-Health Issue Network as Means to Improve Case-Base Learning in Health Sciences Education". *Stud. Health Technol. Inform.* 255: pp.262-266.
- Ricci F.L., Pecoraro F., Luzi D., Consorti F. and Tamburis O. (2020). "A Straightforward Formalization of the HIN Model". *IRPPS Working Paper* 121: pp.1-31.
- Rolón E., Ruiz F., Garcia F. and Piattini M. (2006). "Applying Software Metrics to evaluate Business Process Models". *CLEI Electronic Journal* 9 (1). doi: 10.19153/cleiej.9.1.5.
- Shao J. and Wang Y. (2003). "A new measure of software complexity based on cognitive weights". *Canadian Journal of Electrical and Computer Engineering* 28: pp.69-74.
- Soo L.G. and Jung-Mo Yoon (1992). "An empirical study on the complexity metrics of Petri nets". *Microelectronics Reliability* 32 (3): pp.323-329. doi: 10.1016/0026-2714(92)90061-O.
- Tristono T., Cahyono S.D., Sutomo and Utomo P. (2018). "Investigate the complexity of the control system of the Norwegian traffic light using Petri net model", in *Journal of Physics: Conference Series*, East Java, Indonesia.
- Vanderfeesten I., Reijers H.A., Mendling J., van der Aalst W.M.P. and Cardoso J. (2008). "On a Quest for Good Process Models: The Cross-Connectivity Metric", in *International Conference on Advanced Information Systems Engineering*, Montpellier, France, pp.480-494.